

# The Ultimate MPU Board



1300 Woody Ridge Ct  
Chesapeake, VA 23322

E-mail: [mpusupport@allteksystems.com](mailto:mpusupport@allteksystems.com)

Website: [www.allteksystems.com](http://www.allteksystems.com)

Office (757) 546-0742

**Manual and Users Guide**

Version J



## ***Getting Started***

First let us say thanks again for purchasing The Ultimate MPU Board. The following instructions should allow you to have your pinball machine setup and ready to play quickly. If at any time you are unsure of how to proceed or have a question, STOP. We offer e-mail support at [mpusupport@allteksystems.com](mailto:mpusupport@allteksystems.com) with an ever improving technical support page on our website at [www.allteksystems.com](http://www.allteksystems.com). This would also be a good time to fill out your warranty form. The serial number is located on the label of the IC chip U6 and has a format of a letter and 3 numbers.

## ***Before you plug in The Ultimate MPU Board***

Take a look at Table 1 on the last page of this manual to determine if the clock speed jumpers need to be changed for the game being selected. The jumpers only need to be moved for the later model Stern games. You can also refer to the table below or the legend on the left side of the Ultimate MPU Board.

### JUMPER

CLK SPEED (J6 & J7)

#### LEFT

All Stern MPU-200  
Games starting with Ali

#### RIGHT

All Bally Games

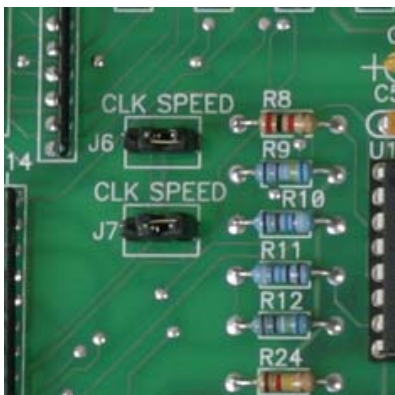

If you have the old MPU board that you feel has the correct dipswitch settings for game features, go ahead and make the Ultimate MPU Board dipswitches (S1-32) the same as your old board. If you choose free play mode you will also have to turn off the credit display game feature switch, which is either switch 20 or 27 depending on the game (refer to your original game manual). One more thing, if you are setting the board up for a Stern machine, you must set the game feature switches. If the game feature switches are left all on or all off, the machine will stay in self-test mode.

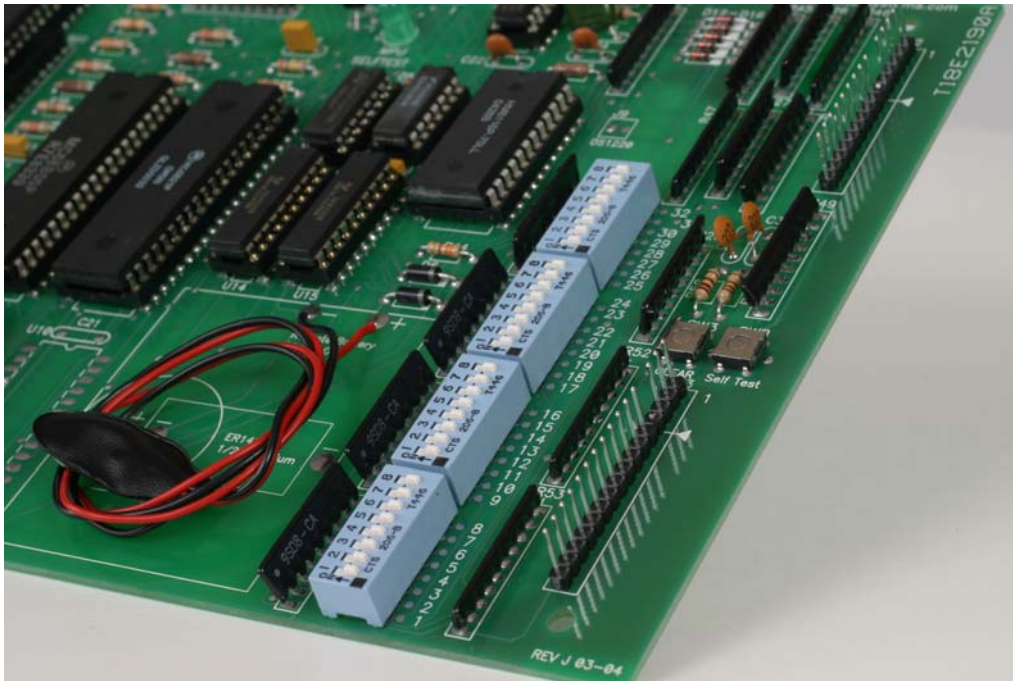

## **Connecting Up**

**\*\*\* Important \*\*\***

Don't apply power until you have checked the +5vdc and +5vac voltage.

It is important to do several things **before you plug in the Ultimate MPU board**. First get a flashlight or a light bright enough to get a good look at the connectors that are hanging in the top left corner of the head of the machine. If you have a Stern machine you might have two extra connectors for the soundboard. Visually inspect the cables for

broken wires or bad pins. If you see any damage you will need to repair this before continuing.

Next, look at the pins and see if you spot any corrosion. If you do, this might not be a showstopper but you should take care of this problem ASAP. Also if you see some corrosion, keep this in mind in case your new board doesn't get your machine working.

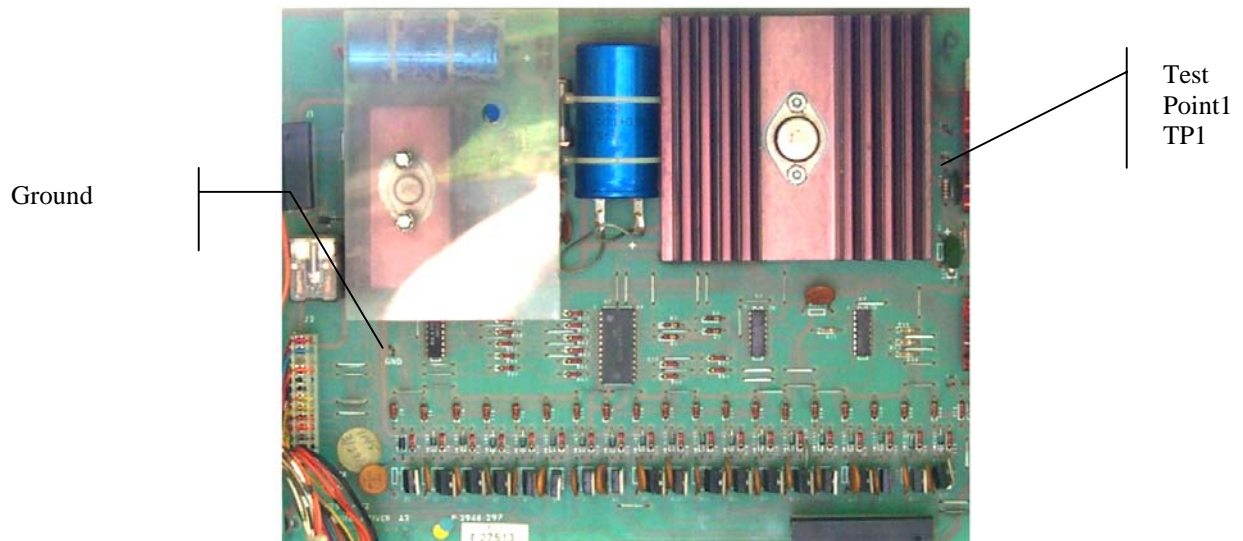

The next preventative measure will be to make sure that the +5 volt supply is OK. Again make sure that the **Ultimate MPU Board is not installed.** Turn the game on. Using a digital voltmeter set to DC, measure the +5 Volts between Test Point 1 (TP1) and the ground Test Point (Gnd) located on the solenoid board in the top right corner in the head. The voltage should be between 4.90 and 5.25 volts. Then place the voltmeter setting to AC; again measure the +5 volts making sure you don't have more the 100mv AC. If you have more then the recommended voltages, see the troubleshooting section before turning on the game. One special note, if your installing this in a Baby Pacman or a Granny and the Gators, use (TP2) to check the +5 Volts. **After you make the measurements, turn off the game.** If you don't have a voltmeter you can do one of several things. See if you can borrow one from a friend or purchase one from Radio Shack (~\$20). You also could

opt to do nothing with the understanding that we don't warranty returns or offer refunds for burned out boards caused by power supply damage.

After you have checked the connectors and power supply, you are ready to mount the new board into the game. Locate the three spacers and the machine screw that you received. If you need to replace your old spacers, do so now.

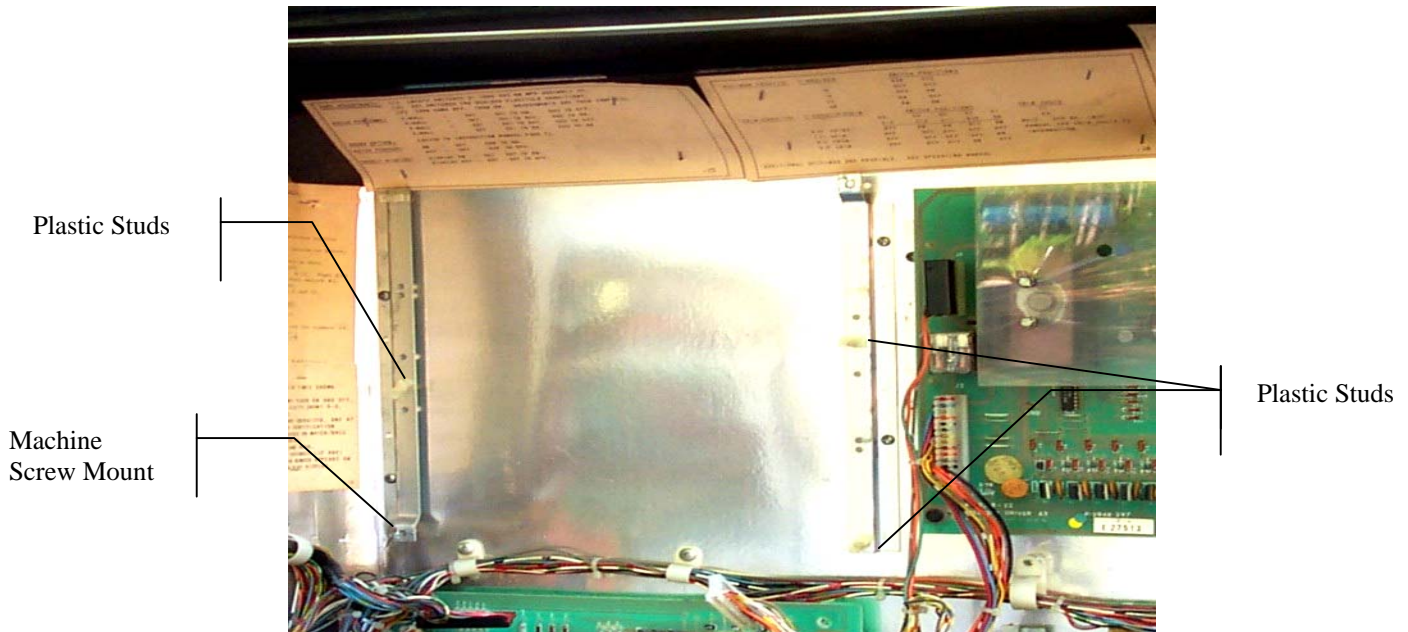

Install the board by placing it on top of the plastic spacers. Then use the machine screw to secure the board in the lower left corner.

Now plug in the connectors, two on the left and two on the right, assuring that the connector keys line up for each connector. If you have a Stern game that has an aux. soundboard, plug this connector into the top connector J5. Remember, on the Ultimate MPU Board the right most side of J5 is pin 1. Make sure you match up the pin 1 of J5 to the aux. soundboards pin 1. Depending on the Stern machine, you might have 2 unused pins on the left side of the connector.

Connect the battery holder to the battery connector. Make sure that you use the supplied battery holder and **not a 9v battery**. Mount the battery holder on the left side of the machine cabinet using the 2 wood screws supplied. Make sure you don't pull on the

connector. Keep the battery connector wires loose. Install a fresh set of batteries making sure to get the polarity correct.

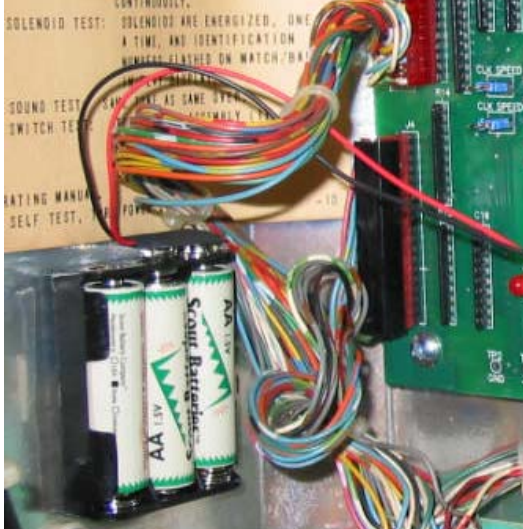

## Power Up

It's now time to set the MPU board for a specific game. Looking at Table 1 again, find your game. If it's a Bally machine then you will need to decide if you want to set the dipswitches for free play or normal game mode. Now configure the Game Select dipswitch (SW2) to the game that you have chosen. If switching from one game to another meaning that you have already had the Ultimate MPU Board in another machine, you should run a memory clear feature. Refer to page 9, for using Memory Clear Feature.

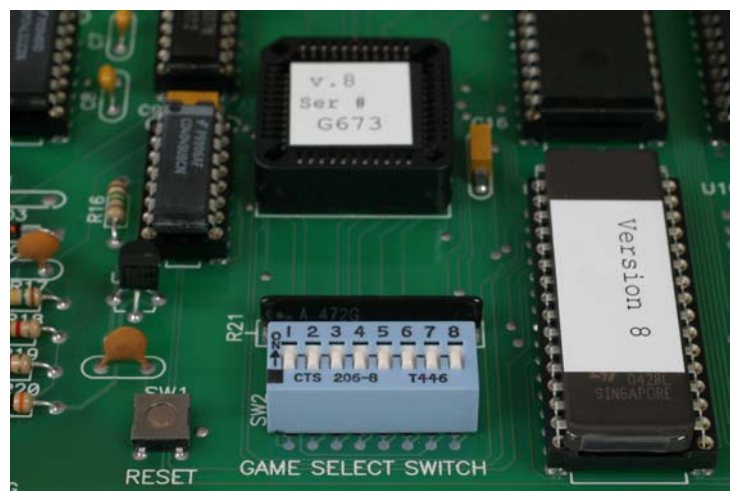

Now we get to the fun part of the manual. With everything checked, set, and plugged in, its time to turn on the game. You should notice two things on The Ultimate MPU Board. You will notice two LED's in the lower right hand side of the board. The Red LED (D17, over voltage protection) should be off and the Green LED should be on (D1, +5vdc). If this is not the case, turn off the game and refer to the troubleshooting section. The other green LED (D4) should light 8 times, with the first flash being the reset pulse, the remaining flashes representing the board self test. After the 8<sup>th</sup> flash, the LED will glow dimly. If you don't see the LED's operating as stated above, proceed to the troubleshooting section of this manual.

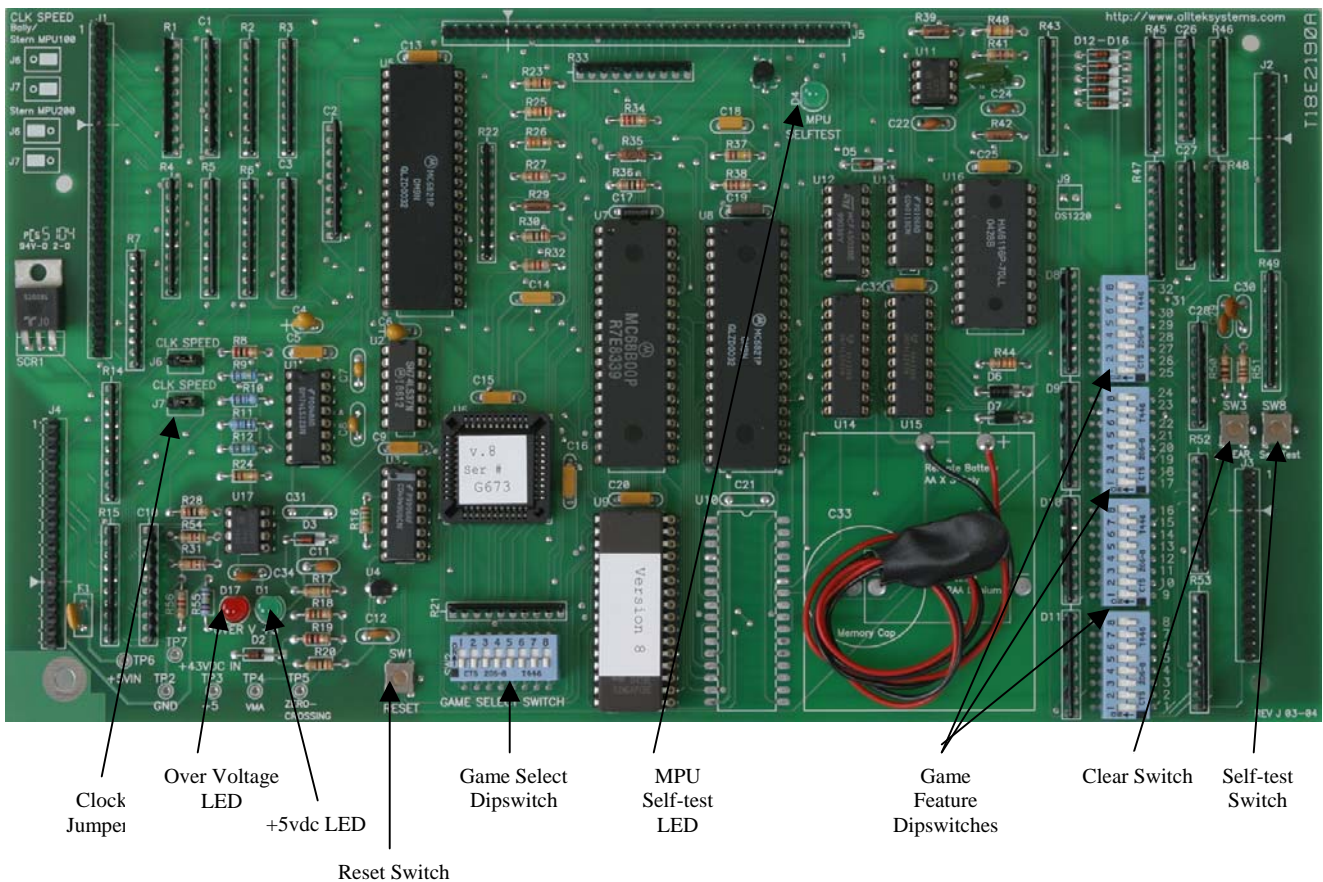

## ***Programming Game Bookkeeping***

At this point your game should be up and running. There is one last important step that needs to be done. You need to set your free play scores and other bookkeeping features. There might also be several settings in your bookkeeping that need to be set for sound options. It is best to refer to your original game manual for this step but just in case you don't have a manual we will try and step you through it.

### **Memory Clear Feature**

You might need to clear all of the memory first by running the memory clear feature. This is useful if you have switched the Ultimate MPU Board from one game to another, but sometimes you need to run this if you see some strange display values or if you have noticed that you can't get into bookkeeping mode. The reason for this is the memory space is used differently from game to game. To run this feature, setup the game select switch as described in Table 1. After you have setup for the memory clear feature, reset the game using the MPU reset switch or turn the game off and then on. You will notice that the green LED will flash on and off about every second. The game memory is now clear. You will now have to set the game select dipswitch back to the game you had it set for before doing the memory clear feature.

### **High Score Feature Adjustments**

The game is designed to award an extra ball or free game at each of three score levels. The recommended levels are on the scorecard of the game. Any level from 10,000 to 9,999,000 can be set, as desired, as long as your game has 7 digit displays. If you have 6 digit displays then you can only go from 10,000 to

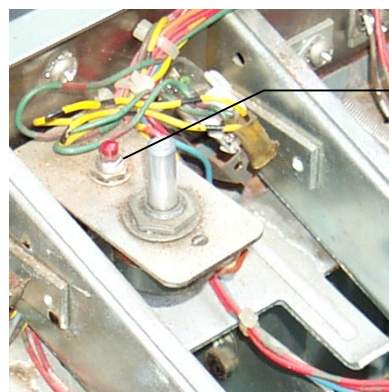

Red  
Self-Test  
Button

990,000. It is also possible to reset or turn off any or all of the levels, if desired.

1. Push and release the Self-Test button on the coin door or use the new Self-Test button (SW8) located on the MPU board. Press the button at one-second intervals approximately six times or until identification number 01 appears on the 'Match/Ball in Play' display.
2. The number on the Player Score Display is the score level. Press the Clear Button (SW3) located on The Ultimate MPU Board to reset the displayed value to 00. Then hold the credit button in until you get the desired replay value. Release the credit button when the desired number appears. Note that the level changes 10,000 points at a time. If the number '00' is left on the displays, the high score feature is eliminated for that level.
3. Repeat steps 1 and 2 for the second and third score levels. The identification numbers '02' and '03' on the 'Match/Ball in Play' display are for the second and third levels, respectively.

### **High Score to Date**

The game is designed to award free games when you beat the current 'High Score to Date'. The adjustment procedure is the same as for the High Score Feature Adjustment, Steps 1 and 2. Continue pushing the Self-Test button until the identification number '04' appears on the 'Match/Ball in Play' display and then do step 2.

### **Bookkeeping Features**

The game is designed to help perform certain accounting functions. The game can display the number of total plays and replays (free games) as well as several other features as follows:

'05' – Current Credits

'06' – Total Plays (Paid & Free Games)

- '07' – Total Free Games
- '08' – Game Percentage
- '09' – Total times 'High Score to Date' is beat
- '10' – Coins dropped thru coin chute #1
- '11' – Coins dropped thru coin chute #2
- '12' – Coins dropped thru coin chute #3\*
- '13' – Number of specials awarded from panel specials only\*
- '14' – Number of minutes of game play\*
- '15' – Number of service credit\*

\* *Not all games have these features*

anu

If desired, you can reset the bookkeeping numbers. The procedure is the same as before but you set the numbers with the credit button.

1. To clear the bookkeeping push the Self-Test button until the identification number '05' appears on the 'Match/Ball in Play' display and then press the clear button on The Ultimate MPU Board.
2. Then repeat step 1 for identification numbers for '06' thru '15', remembering that not all games go to identification number '15'.

### **Feature options '16 thru '22'\***

To setup positions '16' thru '22' push and release the Self-Test button until '16' shows on the 'Match/Ball in Play'. Now press the credit button until you get to the value desired. It is best to use the game's manual for these features, but if you don't have the original manual, then make the desired number 03. Repeat this step until the game goes in to a reset condition. At this point your game is all ready for play but if you made a mistake on any of the settings, you can go through them again and change only the ones that you desire.

\* *Not all games have these features*

## The Enhanced Diagnostics Self-Test Mode

The enhanced diagnostics mode has a burn in test mode that is useful if you want to test out your machine for a period of time. We also offer an inexpensive board, the Ultimate MPU Test Card that will allow you to test individual solenoids, lamps, and displays. The test card plugs on to the J2 connector. This will allow you to test every aspect of the game in very small detail. If you have this option, refer to the Ultimate MPU Test Card Manual for further instructions.

If you don't have this board option you can still place your game in burn-in test mode.

1. Remove the J2 connector from the Ultimate MPU Board.
2. Place the Game Select Switch (SW2) in Enhanced Diagnostics Mode by turning on switches 1 and 2. See table 1 for more info if needed.
3. Turn on the machine
4. You should notice that the 'Player Scores' have a "0" flashing in them.
5. Press the self-test button on the door until you see a "5" on the 'Match/Ball in Play' display.
6. The machine is now in a burn in mode until you turn off or reset the machine.

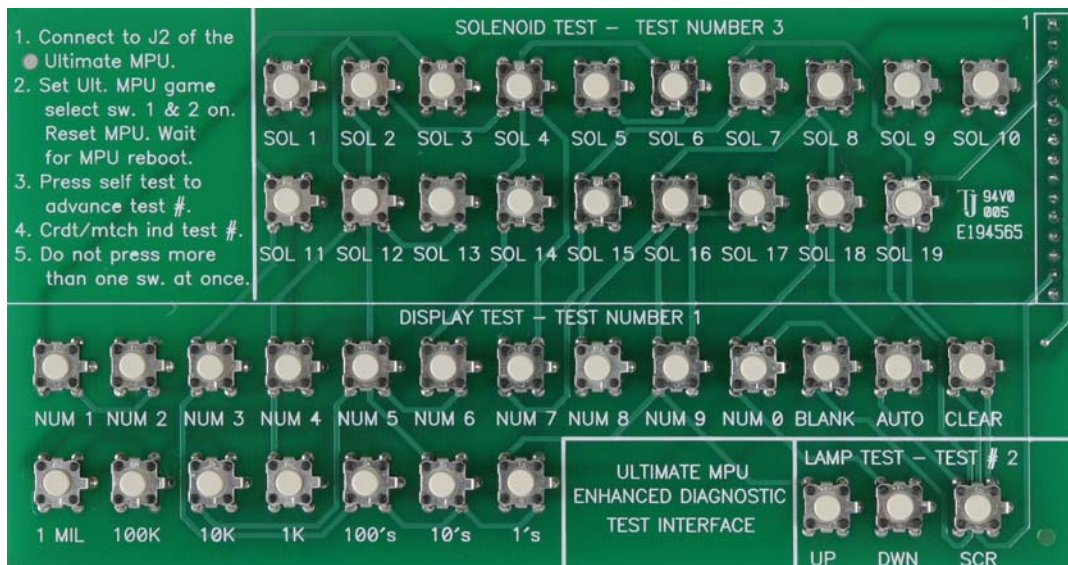

## Optional Ultimate MPU Test Card

## **Troubleshooting Section**

***I turn on the game and nothing happens. None of the game lights or LED's on the Ultimate MPU Board are on.***

- Check that the machine is plugged in.
- Move power plug to a different outlet.
- Check that all of your connectors are connected.

***I turn on the game and nothing happens. I do have game lights but no LED's on the Ultimate MPU Board.***

- Check that all of the connectors are plugged in.
- If you checked the +5 Volts and it was OK, check the +5 volts on The Ultimate MPU Board. You will notice a Test Point labeled +5 volts and Ground. If you don't have it on the board, you are losing the power between your Solenoid Board and your new MPU board.

***I turn on the Game but don't see the green LED flash 8 times. I do have the +5 volt LED on.***

- Remember the first flash is the reset pulse. When you turn on the game you will notice the Self-Test LED turn on, then you will see another flash, then a pause with 5 more flashes, this means you have a +43 volt solenoid power problem. This means that the MPU board J4, pin 15 is not getting +43vdc. Check the +43 volt fuse, wiring from the transformer board, or it could be a bad connector.

***Is it OK that the Self-Test LED is glowing dimly?***

- Yes, this is normal.

***Is there a free play setting for Stern machines?***

- No.

***The game turns on and starts but only the flippers are working.***

- Check the fuse that is located under the playfield.

***I have the MPU board setup for a newer Stern machine and it's running slow.***

- Check that the clock jumpers (J6 & J7) are on the left 2 pins.

***I have the MPU board setup for a Stern machine and the game is stuck in self-test mode.***

- You must have the game feature switches set to something other than all on or all off.

*The games self-test will not allow me to go into bookkeeping mode or*

*The games displays have some strange high score values when I start the game or*

*The display has digits in strange places.*

- Run the memory clear function located in Table 1.

*The +5vdc or +5vac voltages are not correct or*

*The over voltage LED (D17) is on.*

- There are only two important components that make up the +5vdc. The voltage regulator (Q20) and the big capacitor (C23) on the solenoid board. If you have too much AC voltage, then replace the big capacitor. If you have too much DC voltage, then replace the voltage regulator. Recheck the voltages before plugging in the MPU again. Sometimes you might have to replace both components and with the game being over 20 years old, it's not a bad idea to replace both components at this time.

Remember that if you don't feel comfortable working to this level of your game it would be wise to call in a technician to help out. There will be times that you have multiple problems with a game, especially if it has sat idle for sometime. Also don't forget we offer support via email, phone, or website.

**Website:**

<http://www.allteksystems.com>

Email:

[mpusupport@allteksystems.com](mailto:mpusupport@allteksystems.com)

Phone:

(757) 546-0742

**Additional info sites:**

<http://www.marvin3m.com/bally/index.htm>

[http://www.allteksystems.com/mpu/Supplemental\\_Pinball\\_Info.html](http://www.allteksystems.com/mpu/Supplemental_Pinball_Info.html)

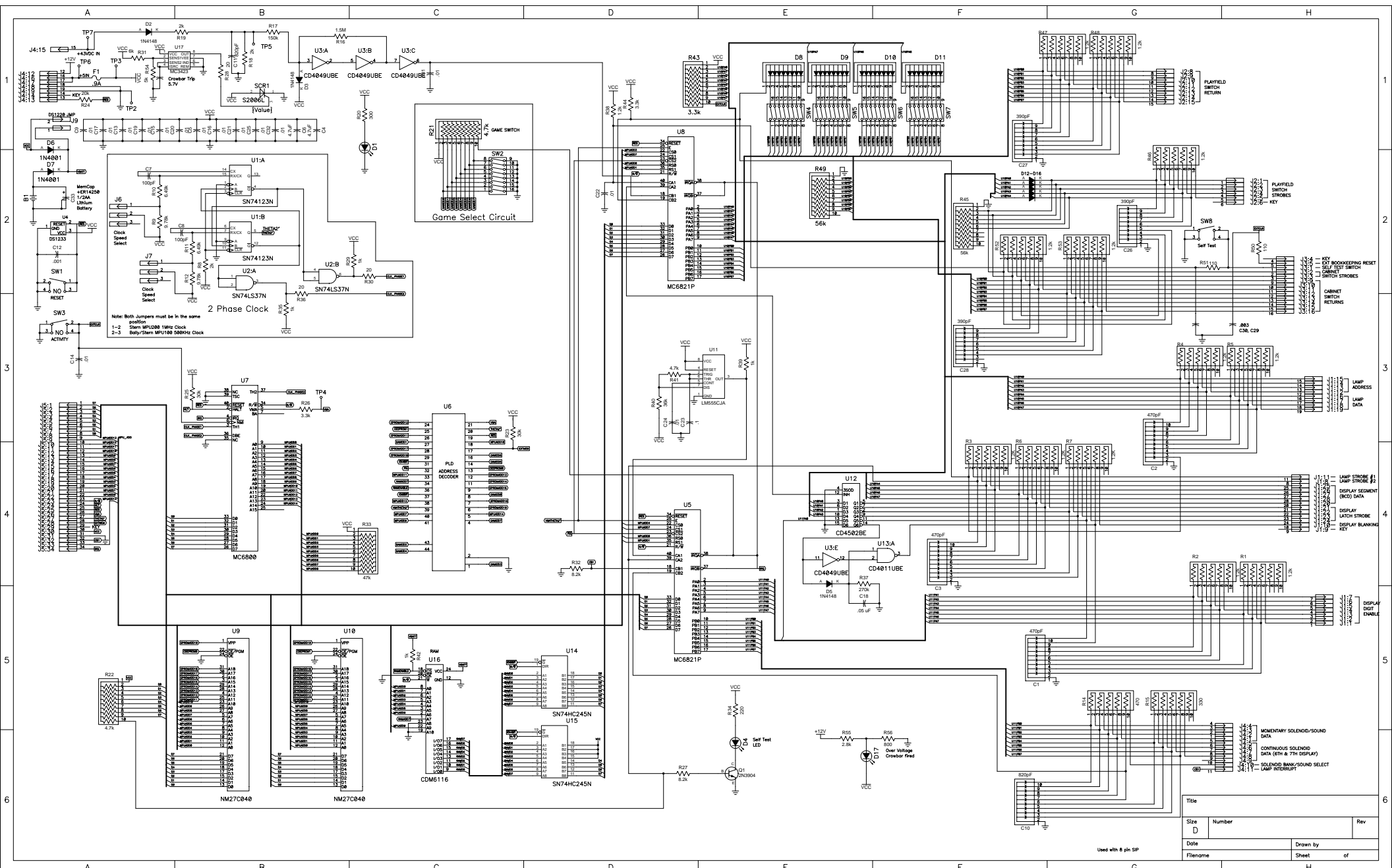

Title		
Size	Number	Rev
Date	Drawn by	
Filename	Sheet of	

Used with 8 pin SP

